



مؤتمر الأزهر الهندسي الدولي العاشر

AL-AZHAR ENGINEERING
TENTH INTERNATIONAL CONFERENCE
December 24 - 26, 2008

Code: M 41

THEORITICAL STUDY FOR COMPACT LIQUID DESICCANT DEHUMIDIFIER/REGENERATOR SYSTEM

M.M. Hammad, R.I. El-Ghanam, R.Y. Sakr, and S.S. Ayad

Mech. Eng. Dept., Shoubra Faculty of Engineering, Benha University
108 Shoubra Street, Cairo, Egypt

rsakr85@yahoo.com

ABSTRACT:

Air may be dehumidified when it is brought into contact with a suitable liquid desiccant. Different types of liquid desiccants are available in the market and the application of the proper desiccant in hot humid climates would improve the dehumidification effectiveness. The driving potential for a dehumidification process is the difference in the pressure of the water vapor in the air and the water vapor saturation pressure corresponding to the air-desiccant solution interfacial temperature and concentration of water above the desiccant. The vapor pressure of a liquid desiccant is a function of its temperature and concentration. Among the various desiccants available, lithium chloride, lithium bromide, calcium chloride, and triethylene glycol have received much attention. The present study aims to evaluate numerically the performance of the proposed liquid desiccant dehumidifier system that utilizes calcium chloride solution as a liquid desiccant. The performance parameters for the air dehumidifier were the reduction ratio of the air humidity ratio and the dehumidifier effectiveness.

Several benchmarks were carried out under the following operating conditions: The cooling water temperature (10°C-18°C), desiccant solution temperature (26°C-33°C), air flow rate (3.4-6 l/s), air inlet temperature (38°C-51°C), air inlet humidity ratio (21-25 g_w/kg_{da}), desiccant solution mass flow rate (0.04-0.13 kg/s), desiccant solution to air mass flow rate ratio (10-26), heating water temperature (42°C-51°C), and desiccant solution concentration (20% -45%).

The results show that the humidity ratio at the exit from the dehumidifier decreases with increasing the desiccant solution concentration and with decreasing of the desiccant solution temperature. The desiccant solution moisture content decreases with increasing of the desiccant solution temperature and mass flow rate, but it decreases with decreasing of the air inlet humidity ratio. Also, the air temperature leaving the dehumidifier decreases with increasing the desiccant solution concentration and the air inlet humidity ratio, but it decreases with decreasing of the desiccant solution temperature. The desiccant solution temperature decreases with increasing the desiccant solution concentration and with decreasing both of the desiccant mass flow rate and the cooling water temperature, but it is not affected with the air inlet humidity ratio. The desiccant solution moisture content gain increases with increasing each of the desiccant solution concentration, the air inlet humidity

THEORITICAL STUDY FOR COMPACT LIQUID DESICCANT DEHUMIDIFIER/REGENERATOR SYSTEM

ratio and the air mass flow rate. It also increases with decreasing desiccant solution mass flow rate and temperature. Also the results show that both of the dehumidifier reduction ratio of the air humidity ratio and the effectiveness increase with the increase of the heating water temperature, the desiccant solution mass flow rate, the desiccant solution to air mass flow rate ratio and the desiccant concentration. Both the reduction ratio of the air humidity ratio and the effectiveness of the dehumidifier decrease with the increase of the cooling water temperature, the desiccant solution temperature and of the air flow rate. The performance parameters were almost unaffected with the inlet air temperature. The dehumidifier reduction ratio of the air humidity ratio slightly increases with the increase of the inlet air humidity ratio, but the dehumidifier effectiveness is almost unchanged with the increase of the inlet air humidity ratio.

Key words: liquid desiccant – dehumidifier – regenerator – heat and mass transfer.

1. INTRODUCTION:

Due to the low pressure drop of the air flow across the liquid desiccant materials, they can be used for the purposes of filtration to remove the dust, the simultaneous cooling during dehumidification. The use of liquid desiccants requires lower regeneration temperature compared to solid desiccants as well as the possibility of heat exchange between spent and regenerated desiccant streams. The liquid desiccants have many potential areas of application. They can be used for: drying of grains and crops, controlling the ripening of fruits, in storage compartments to prevent corrosion, mildew and fermentation, drying of gases before storage, in energy systems, concentration of fruits juices, and power generation. Both solid and liquid desiccants are extensively used for dehumidification and cooling. Some of the merits of liquid desiccant systems include improved indoor air quality, acting as disinfectants, being single regenerator for multiple conditioners and flexibility in its location. However, common problems involving carryover of solutions into air stream, crystallization of salts and corrosion by salts are expected. Nevertheless, the liquid desiccant cooling systems have been proposed as alternatives to the conventional vapor compression cooling systems to control air humidity especially in hot and humid areas.

The earliest known liquid desiccant system was suggested and experimentally tested by Lof [1], who used triethylene glycol as the hygroscopic solution. In this system, air was dehumidified and simultaneously cooled in an absorber and is then evaporatively cooled. The concept of air dehumidification by a liquid desiccant was brought again to the interest of many investigators in the late of 1970s and early 1980s.

Radhwan et al. [2] used one dimensional modeling to simulate the process occurring in a counter flow air-calcium chloride liquid desiccant packed bed dehumidifier and to predict the performance of the bed at different air and liquid desiccant inlet conditions, air and liquid flow rates and bed lengths. It was found that the inlet temperature of the liquid desiccant has strong effect on the other parameters, while the air inlet temperature has a negligible effect. A modification of the packed bed dehumidifier geometry has been carried out by Khan and Ball [3]. In this modification the packed material was replaced by several circuits of multi row, externally finned tube coils that were placed in the conditioner unit.

Rix et al. [4] proposed and investigated another absorber which had no cooling effect. This absorber consists of several parallel, vertical, cotton sheets down which the LiCl solution moves and between which air flows upwards. Dehumidification occurs at the surfaces of the cotton sheets, where the air comes into contact with the lithium chloride solution. The diluted LiCl solution drips off the bottom of the sheets into a reservoir which, in turn, feeds the regenerator. There was a scope for improving the performance of the device

THEORITICAL STUDY FOR COMPACT LIQUID DESICCANT DEHUMIDIFIER/REGENERATOR SYSTEM

significantly, and the areas where further investigations were likely to be most productive have been identified.

A simple model for the preliminary design of an air dehumidification process occurring in a packed bed using liquid desiccant through dimensionless vapor pressure and temperature ratios is developed by Gandhidasan [5]. A linear approximation made to find out the dependence of equilibrium humidity ratio on the solution temperature in a simplified analysis of a packed bed liquid desiccant dehumidifier/regenerator is proposed by Chengqin et al. [6]. In this analysis, new parameters were defined and the original equations were rearranged to obtain two coupled ordinary differential equations. Also Chengqin et al. [7] presented a theoretical study on the analysis of the process of adiabatic liquid desiccant dehumidification/regeneration with slug flow assumption. They developed a controlling equation for the quasi-equilibrium processes where the two fluid streams are in contact in quasi-equilibrium conditions. Results from this equation with numerical integration for the solution are presented as a process curves on a psychrometric chart. Two of these curves are found to be characteristics of typical types of adiabatic dehumidification/regeneration processes. One for a small enthalpy change of air and low mass flow rate of solution and the other with a small concentration change at high mass flow rate of solution. Pietruschka et al. [8] presented new desiccant cooling cycles to be integrated in residential mechanical ventilation systems. The process shifts the air treatment completely to the return air side, so that the supply air can be cooled by a heat exchanger. Purely sensible cooling encountered in this case is an essential requirement for residential buildings where no good maintenance is guaranteed for supply air dehumidifiers.

Mesquita et al. [9] developed mathematical and numerical models for internally cooled liquid desiccant dehumidifiers using three different approaches. The first approach is based on heat and mass transfer correlations. The second numerically solves by the finite difference method the differential equations for energy and species assuming constant film thickness. The third approach introduces a variable film thickness. All approaches assume fully developed laminar flow for the liquid and air streams. Liu et al. [10] presented analytical solutions for the air and desiccant parameters inside parallel, counter, and cross flow packed bed dehumidifier/regenerator under reasonable assumptions based on heat and mass transfer models. The analytical solutions show good agreement with the corresponding numerical results and experimental findings. A theoretical model based on introducing NTU as input parameter to simulate the heat and mass transfer processes in cross flow in packed bed dehumidifier/regenerator using liquid desiccant was developed by Liu et al. [11]. The temperatures predicted by the theoretical model agree with the experimental results. They also, investigated theoretically in [12], the heat and mass transfer between air and liquid desiccant in cross flow packed bed dehumidifier. They presented analytical solutions of air and desiccant parameters as well as enthalpy and moisture efficiencies. Good agreement is shown between the analytical solutions and the numerical or experimental results.

Mohan et al. [13] utilized the psychrometric equations and liquid desiccant property data to introduce heat and mass transfer analysis for the dehumidifier and regenerator columns in counter flow configuration. A detailed study of performance characteristics at low solution to air flow rate ratio for the absorber and regenerator columns confirms the requirement of the desiccant loop for additional dehumidification of the conditioned air. Liu and Jiang [14] investigated theoretically the combined characteristics of heat and mass transfer processes between air and desiccant in packed bed dehumidifier/regenerator. Hassan and Hassan [15] studied theoretically the heat and mass transfer analysis between a thin liquid layer of the proposed liquid desiccant and the air flowing through rectangular channel. They used calcium chloride solution mixed with calcium nitrate in different weight combinations as a proposed liquid desiccant.

THEORITICAL STUDY FOR COMPACT LIQUID DESICCANT DEHUMIDIFIER/REGENERATOR SYSTEM

Ren et al. [16] proposed internally cooled or heated liquid desiccant–air contact units for effective air dehumidification or desiccant regeneration, respectively. One-dimensional differential equations were utilized in their study to describe the heat and mass transfer processes with parallel/counter flow configurations. The heat and mass transfer performances were analyzed and some guidance to improve the unit design was provided. Jain and Bansal [17] proposed a comprehensive comparative parametric analysis of packed bed dehumidifiers for three commonly used desiccant materials viz. triethylene glycol, lithium chloride and calcium chloride, using empirical correlations for dehumidification effectiveness from the literature. The analysis reveals significant variations and anomalies in trends between the predictions by various correlations for the same operating conditions, and highlights the need for benchmarking the performance of desiccant dehumidifiers.

This paper is an extension to the experimental study performed by Hammad el al. [18] where it introduces a numerical model based on heat and mass balances between air and desiccant solution streams to evaluate the performance of the dehumidifier of compact uni-shell liquid desiccant dehumidifier/regenerator system and properties distributions along the dehumidifier height under different operating conditions.

2. MATHEMATICAL MODELING:

Many researchers have performed experimental tests on the heat and mass transfer performance of the dehumidifier or regenerator. The inlet and outlet parameters of the air and the desiccant through the dehumidifier/regenerator can be easily measured, while the temperature and concentration distributions within the dehumidifier /regenerator are difficult to measure directly. Numerical simulation has advantages in studying the temperature and concentration fields within the heat and mass transfer devices.

2.1 Geometrical Description of the Proposed System

The proposed system under investigation is shown in Fig. (1). It consists of a uni-shell unit which is divided into three chambers. The right chamber is the dehumidifier, the left chamber is the regenerator and the middle one is for the heat exchanger. A block diagram of the proposed system is illustrated in Fig. (2). The dehumidifier and the regenerator contain tubes arranged in a staggered configuration in the hatched zone between height Z_1 to height Z_2 as shown in Fig. (3). Cold water flows in the tubes in the dehumidifier side to cool the process air while hot water flows in the tubes in the regenerator side to heat the regeneration air. The heat exchanger is located in the space between the dehumidifier and the regenerator. The dehumidifier, regenerator and heat exchanger sections of the shell are filled with liquid desiccant solution to fully submerge the heat exchanger tubes as well as hot and cold water tubes. Detailed descriptions of the main components of the system are given below.

The dehumidifier is the right section of the shell, Fig. (1). The process air is blown through it from the bottom as bubbles while the liquid desiccant solution flows from the bottom in a co-current arrangement. In addition to the agitation which is induced in the solution by the blowing of the air bubbles. The air bubbles provide a large surface area in a relatively small volume that improves the heat and mass transfer processes. The moisture from the air is absorbed by the solution. The solution is diluted by moisture absorption and the diluted solution leaves the dehumidifier and it is pumped to the heat exchanger where it is preheated by the concentrated solution. The process air is dehumidified and cooled, then delivered to the conditioned space.

The regenerator is the left section of the shell, Fig. (1). The regeneration air is blown through from the bottom of the regenerator through a number of distribution holes as bubbles while the liquid desiccant solution flowing from the dehumidifier through the heat exchanger to enter the regenerator also from the bottom to produce a co-current flow between the

THEORITICAL STUDY FOR COMPACT LIQUID DESICCANT DEHUMIDIFIER/REGENERATOR SYSTEM

regeneration air and the solution in the regenerator. Process air is introduced to the dehumidifier in a manner similar to that of the regenerator. Heat transfer occurs between the air and the desiccant solution due to the temperature difference between the two streams. The heat transfer also occurs between the desiccant solution and the hot water. Mass transfer also takes place between both streams due to the difference in the vapor pressure. Warm, concentrated solution leaves the top of the regenerator and passes through a heat exchanger where it is cooled by heat transfer to the weak solution leaving the dehumidifier through the heat exchanger to the regenerator. The cold diluted solution is pumped from the dehumidifier top to the heat exchanger right side and then is heated by the concentrated solution which passes from the regenerator top around the heat exchanger tubes and then flows to the bottom of the dehumidifier through an overflow tube; Fig. (1). Table (1) shows the geometric parameters for the present model.

Table: (1) The values of the geometric parameters

$R = 350 \text{ mm}$	$d_{h/cw} = 16 \text{ mm}$	$d_{hc} = 12 \text{ mm}$	$a = 80 \text{ mm}$
$S_{xwt} = 40 \text{ mm}$	$S_{zhe} = 40 \text{ mm}$	$L = 1200 \text{ mm}$	

For steady-state operation, the rate at which moisture is removed from the air in the dehumidifier will be equal to the rate at which the moisture is transferred from the dehumidifier to the regenerator by the flow of liquid desiccant. This will, in turn, be equal to the rate at which moisture is added to the regeneration air which is heated and humidified in the regenerator

The mathematical modeling of the dehumidifier and the regenerator is the same except in the specification of the inlet conditions of the air and liquid desiccant.

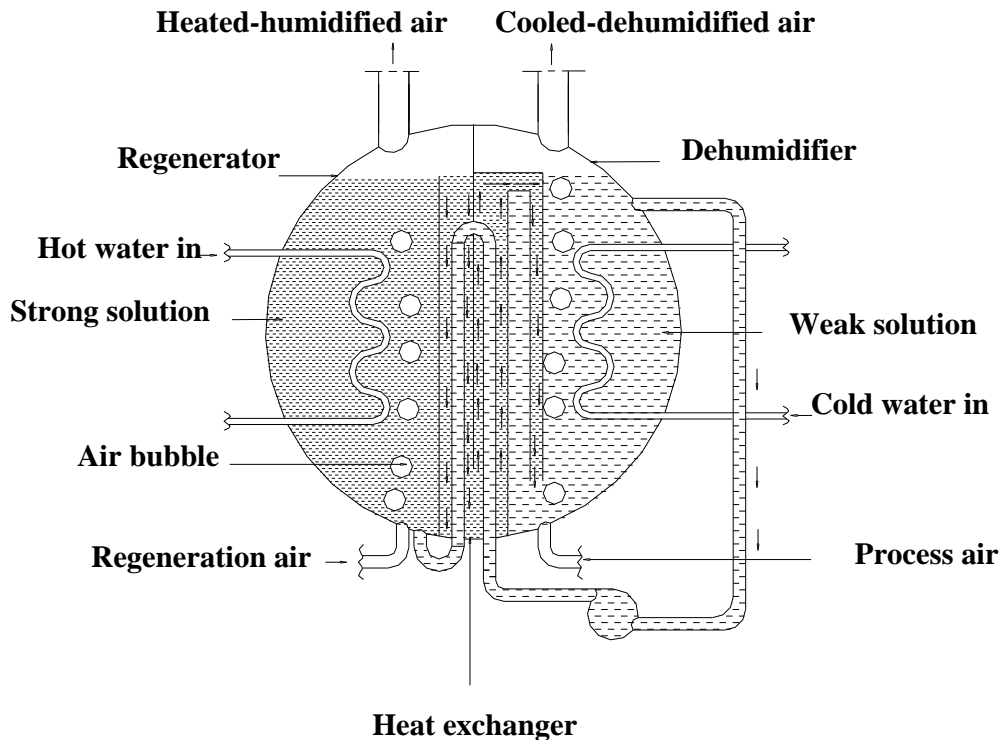

Fig. (1) The proposed system for dehumidifier –heat exchanger-regenerator system

THEORITICAL STUDY FOR COMPACT LIQUID DESICCANT DEHUMIDIFIER/REGENERATOR SYSTEM

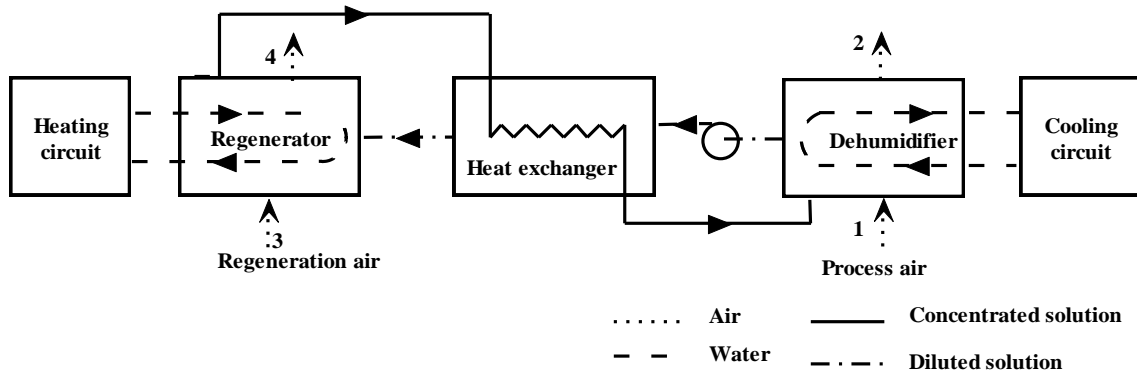

Fig. (2) Block diagram of the proposed system

Consider the geometry of the shell depicted in Fig. (4). The shell has a radius R and is divided into three compartments as described before. These three compartments are: the regenerator, the heat exchanger and the dehumidifier. The heat exchanger compartment has a constant width of $2a$ as shown in the figure. Consider now the dehumidifier compartment. At height z measured from lowest position of the shell, the width of the dehumidifier compartment is b . This width of course varies with the height z due to the circular nature of the shell surface. From Fig. 4, the width b is determined in terms of R , Z and a as follows:

$$b = -a + \sqrt{2Rz - z^2} \tag{1}$$

The staggered configuration for the hot/cold water tubes is illustrated in Fig. (5). The arrangement has a longitudinal pitch s_{xwt} , transverse pitch s_{zwt} and the tube outer diameter $d_{h/cw}$. To calculate the voidage ϕ_{wt} of the tubes, i.e. the fraction of the volume occupied by the tubes, the area occupied by five tubes which are arranged as shown in the figure is considered. The volume of this area is $2 s_{xwt} s_{zwt} L$ and the volume occupied by the tubes is $2 \frac{\pi}{4} d_{h/cw}^2 L$. Therefore, the voidage of the tubes ϕ_{wt} is calculated by the following relation:-

$$\phi_{wt} = \frac{\pi d_{h/cw}^2}{4 s_{xwt} s_{zwt}} \tag{2}$$

Similarly, the area of the three tubes in the heat exchanger side is shown in Fig. (6). The width of this area is a , the height is $2 s_{zhe}$ and the outer tube diameter d_{he} . The volume of this area is $2 s_{zhe} aL$ and the volume occupied by the tubes is $2 \frac{\pi}{4} d_{he}^2 L$.

$$\phi_{het} = \frac{\pi d_{he}^2}{4 a s_{zhe}} \tag{3}$$

2.3 Governing Equations and Boundary Conditions:

Heat and mass balances for the dehumidifier will be carried out to derive the governing equations for the variation of the humidity ratio of the air W , the moisture content of the solution ζ , the air temperature T_a and the solution temperature T_s along the dehumidifier and the regenerator height, based on the following assumptions:

- i) One dimensional flow in z direction.
- ii) Steady state process.
- iii) Negligible tube wall thermal resistance and fouling effects.
- iv) Uniform properties for both air and liquid desiccant over the working range.

THEORITICAL STUDY FOR COMPACT LIQUID DESICCANT DEHUMIDIFIER/REGENERATOR SYSTEM

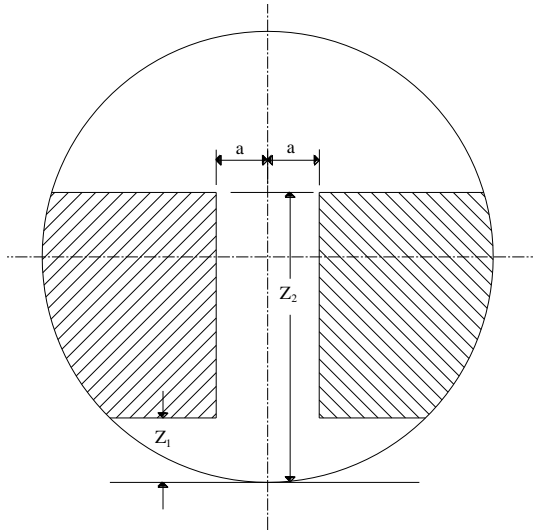

Fig. (3) Geometry of tube matrix

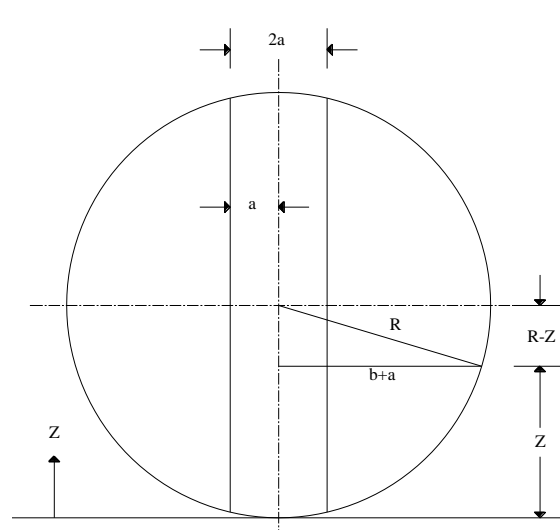

Fig. (4) Geometry of the shell

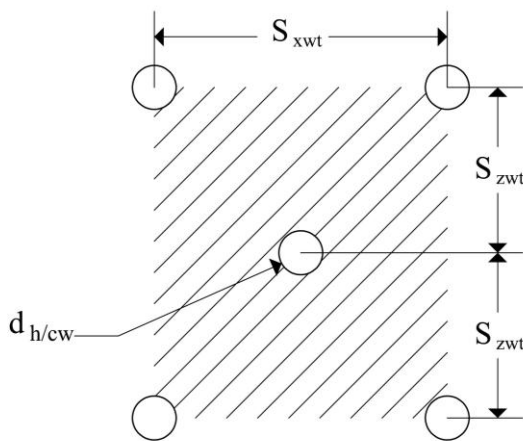

Fig. (5) Geometry of hot/cold water tubes

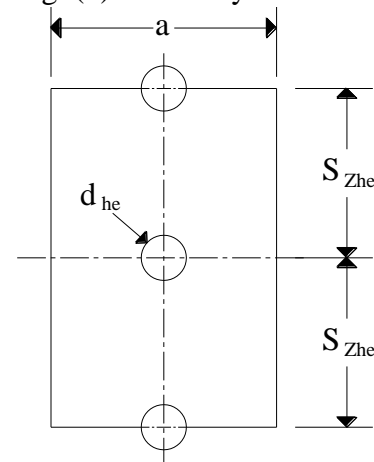

Fig. (6) Geometry of heat exchanger tubes

- v) Uniform tube surface temperature.
- vi) Negligible bubble break up and coalescence.
- vii) Negligible resistance to mass transfer inside the bubble.
- viii) Negligible heat loss to the surroundings. Kinetic and potential energy changes are also negligible.
- ix) Perfect gas approximation for water vapor.
- x) Negligible binding energy for desiccant liquid and equal values of heat and mass transfer areas.
- xi) No direct heat exchanger between the air bubbles and the cold water tubes.

Applying both mass and heat balances for the differential control volume, $dV = (1 - \phi_{wt})bLdz$ of the dehumidifier, which is illustrated in Fig. (7), the governing equations for the proposed system can be written as follows:

The mass balance for the moisture in the air

$$\frac{dW}{dz} = \frac{-h_D A_m}{u_a} (1 - \phi_{wt})(W - W_e) \quad (4)$$

The mass balance for the moisture in the solution

$$\frac{d\zeta}{dz} = \frac{\rho_a}{\rho_s} \frac{h_D A_m}{u_s} (1 - \phi_{wt})(W - W_e) \quad (5)$$

THEORITICAL STUDY FOR COMPACT LIQUID DESICCANT DEHUMIDIFIER/REGENERATOR SYSTEM

The energy balance for the air side

$$\frac{dT_a}{dz} (c p_a + c p_v W) = \frac{h_D A_m}{u_a} (1 - \phi_{wt}) (W - W_e) (i_{fg,0} + c p_v T_a - i_{fg}) - \frac{h_a A_h}{\rho_a u_a} (1 - \phi_{wt}) (T_a - T_s) \quad (6)$$

The energy balance for the solution side

$$\frac{dT_s}{dz} (c p_s + \zeta c p_w) = - \frac{\rho_a h_D A_m}{\rho_s u_s} (1 - \phi_{wt}) (W - W_e) c p_w T_s + \frac{h_a A_h}{\rho_s u_s} (1 - \phi_{wt}) (T_a - T_s) - \frac{h_t A_t}{\rho_s u_s} (1 - \phi_{wt}) (T_s - T_w) \quad (7)$$

Equations (4-7) represent a set of first order ordinary differential equations of four unknowns W , ζ , T_a , and T_s with initial value boundary conditions (at $z = 0$; $W=W(0)$, $\zeta = \zeta(0)$, $T_a = T_a(0)$, and $T_s = T_s(0)$).

The value W_e in Equations (4) and (5) refers to the equilibrium humidity ratio of the air, which is the humidity ratio of air at equilibrium condition that is defined as the condition where no either heat or mass transfer between the air and the desiccant solution occurs.

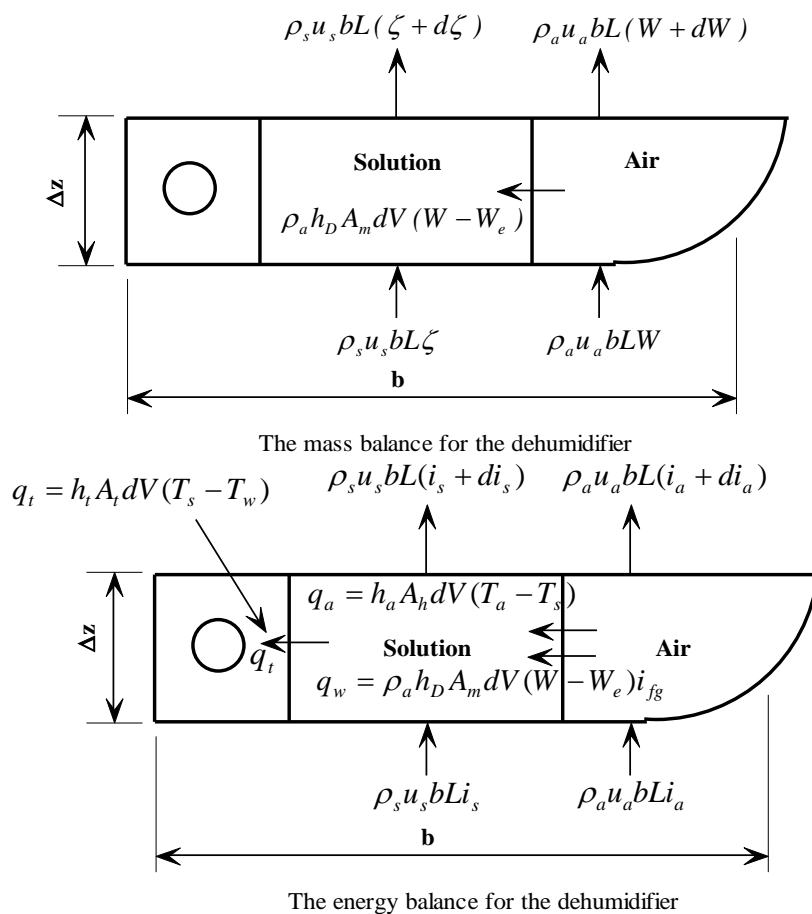

Fig. (7) The mass and energy balance for the dehumidifier side

2.4 The determination of the Governing Equations Coefficients

The coefficients of the governing equations include operating, geometric and transport parameters and fluid properties. So, the followings show the equations that used in determining both the fluids properties and transport parameters.

2.4.1 Properties of the air and desiccant solutions

The thermodynamic properties of moist air and desiccant solution in S.I. units are calculated using the following equations;

Air properties, [19].

$$\rho_a = 1.2521 - 0.003T_a \quad (8a)$$

$$\mu_a = 1.72 \times 10^{-5} + 4.63 \times 10^{-8}T_a \quad (8b)$$

$$C_{p_a} = 1004.8 + 0.0696T_a \quad (8c)$$

$$k_a = 0.0242 + 7 \times 10^{-5}T_a \quad (8d)$$

$$Pr_a = 0.7133 - 0.000167T_a \quad (8e)$$

Calcium Chloride solution properties, [2]

$$\rho_s = 990.857x - 0.5T_s + 937.425 \quad (9a)$$

$$\mu_s = 0.0122x - 4.3 \times 10^{-5}T_s - 1.37 \times 10^{-4} \quad (9b)$$

$$c_{p_s} = 4027 + 1.859T_s - 5354x + 3240x^2 \quad (9c)$$

$$k_s = -0.17x + 1.25 \times 10^{-3}T_s + 0.58 \quad (9d)$$

2.4.2 Equilibrium condition of the air-desiccant solutions

The air in contact with a solution of desiccant is said to be in equilibrium state when there is no heat and mass transfer between the air and the solution. Under this condition the air temperature would be equal to that of the desiccant solution and the partial pressure of water vapor in the air would be p_{wx} which is the saturation pressure of the solution of concentration x at the desiccant solution temperature, and is given by the following equations; [20].

$$P_{wo} = 0.0159T_s^{1.6438} \quad (10)$$

$$P_{wx} = P_{wo}(1.146 - 1.76x) \quad (11)$$

$$W_e = 0.62185 \frac{P_{wx}}{P - P_{wx}} \quad (12)$$

2.4.3 Supporting Equations

The supporting equations are listed below. Orifice Reynolds number is calculated to compute the average bubble diameter and the average specific interfacial surface for mass transfer. Also air Reynolds number, Schmidt number and Sherwood number are calculated to compute the mass transfer coefficient, [21].

The total orifices area in (m^2) can be calculated as:

$$A_o = n \times \frac{\pi}{4} (d_o)^2 \quad (13)$$

The mass flow rate of air in (kg/s) for one orifice is given by:

$$m_o = \frac{\dot{m}_a}{n}, \quad n = 240 \quad (14)$$

The orifice Reynolds number is given by;

THEORITICAL STUDY FOR COMPACT LIQUID DESICCANT DEHUMIDIFIER/REGENERATOR SYSTEM

$$Re_o = \frac{4m_o}{\pi d_o \mu_a} \quad (15)$$

The average bubble diameter in (m) is calculated from the following correlation:

$$d_b = 0.0071 Re_o^{-0.05} \quad (16)$$

The air and the solution mass flow rate in (kg/s) are given as:-

$$m_a = \rho_a A_o (1 - \varphi_{wt}) u_a \quad (17)$$

$$m_s = \rho_s A_s (1 - \varphi_{wt}) u_s \quad (18)$$

The average specific interfacial surface area in (m²/m³) for mass transfer is given by:-

$$A_m = \frac{6\phi_G}{d_b} \quad (19)$$

Where;

ϕ_G : is the gas holdup volume fraction.

The characteristic length for calculating Reynolds and Nusselt numbers; D is given by:

$$D = \sqrt{n \times d_b^2} \quad (20)$$

$$u_a = \frac{\dot{m}_a}{\rho_a A_o} \quad (21)$$

$$Re_{a,D} = \frac{D u_a \rho_a}{\mu_a} \quad (22)$$

$$Nu = 0.683 (Re_{a,D})^{0.466} (Pr)^{1/3} \quad (23)$$

$$h_a = \frac{Nu k_a}{D} \quad (24)$$

The Schmidt number is given by:

$$Sc_s = \frac{\mu_s}{\rho_s \alpha_s} \quad (25)$$

Where;

α_s : is the desiccant solution diffusivity, m²/s.

The Sherwood number is calculated from the following correlation:

$$Sh_s = \frac{h_D d_b}{\alpha_s} = 2 + 0.0187 Re_a^{0.779} Sc_s^{0.546} \left(\frac{d_b g^{\frac{1}{3}}}{\alpha_s^{\frac{2}{3}}} \right)^{0.116} \quad (26)$$

$$A_t = N \pi d L / V \quad (27)$$

Where; V is the dehumidifier volume.

$$u_s = \frac{\dot{m}_s}{\rho_s A_s} \quad (28)$$

$$\Delta T_a = T_{ai} - T_{ao} \quad (29)$$

$$Q_{water} = \dot{m}_w C_{p,w} \Delta T_w \quad (30)$$

$$h_t = Q_{water} / A_{tubes} \Delta T \quad (31)$$

2.5 The dimensionless governing equations:

Consider the following dimensionless parameters where z_r , T_r , are reference values of the length and the temperature respectively

$$z^* = \frac{z}{z_r}, T_a^* = \frac{T_a}{T_r}, T_s^* = \frac{T_s}{T_r}$$

Substituting in the above values in the governing equations for the four dependent variables $W, \zeta, T_a,$ and T_s yields

$$\frac{dW}{dz^*} = -(Sh_a^*/Pe_a)(W - G_1) \tag{32}$$

$$\frac{d\zeta}{dz^*} = R_5(Sh_s^*/Pe_s)(W - G_1) \tag{33}$$

$$\frac{dT_a^*}{dz^*}(1 + R_1W) = (Sh_a^*/Pe_a)(W - G_1)(i_{fg}^* + R_1T_a^*) - (Nu_a^*/Pe_a)(T_a^* - T_s^*) \tag{34}$$

$$\begin{aligned} \frac{dT_s^*}{dz^*}(1 + R_2\zeta) = & -R_5R_2(Sh_s^*/Pe_s)(W - G_1)T_s^* + R_3(Nu_s^*/Pe_s)(T_a^* - T_s^*) \\ & - h^*R_3(Nu_a^*/Pe_s)(T_s^* - G_2) \end{aligned} \tag{35}$$

Where;

$$Sh_a^* = \frac{z_r^2 h_D A_m}{\alpha_a} (1 - \phi_{wr}), Pe_a = \frac{u_a z_r}{\alpha_a}, Pe_s = \frac{u_s z_r}{\alpha_s}, Nu_a^* = \frac{z_r^2 h A_m}{k_a} (1 - \phi_{wr}), h^* = \frac{h_t A_t}{h A_m},$$

$$i_{fg}^* = \frac{i_{fg,0} - i_{fg}}{Cp_a T_r}, R_1 = \frac{cp_v}{cp_a}, R_2 = \frac{cp_w}{cp_s}, R_3 = \frac{k_a}{k_s}, R_4 = \frac{cp_a}{cp_s}, R_5 = \frac{k_a cp_s}{k_s cp_a} = \frac{R_3}{R_4} \quad G_1 = W_e,$$

$G_2 = T_w^*$; and the boundary conditions are:

$$at z^* = 0 \quad W_a = W_{ai}, \zeta = \zeta_{si}, T_a^* = T_{ai}^* = 1, T_s^* = T_{si}^* = 0.65 \text{ to } 0.775 \tag{36}$$

Equations (32-35) together with the corresponding boundary conditions in Eq. (36) are solved simultaneously by fourth order Runge-Kutta method.

3. MODEL VALIDATION:

To check the consistency and reliability of the present theoretical analysis, comparisons of the present model predictions are made with experimental results performed by Hammad el al. [18] which are illustrated in figures (8) to (11). The effect of desiccant solution temperature on the dehumidifier effectiveness for desiccant solution concentration of 25% is illustrated in Fig. (8). It is noticed from the figure that the effectiveness decreases with the increasing of the desiccant solution temperature. Fair agreement between the present predictions and the experimental results is noticed, the difference being about 13.3% at (T_{si}/T_{ai}) of 0.67 and 4.35% at (T_{si}/T_{ai}) of 0.75. The dehumidifier effectiveness is defined as:

$$\varepsilon = \frac{W_i - W_o}{W_i - W_e}$$

The effect of the cooling water temperature on the dehumidifier effectiveness is illustrated in Fig. (9) at higher concentration solution of 35%. It is observed from the figure that the dehumidifier effectiveness decreases with increasing the cooling water temperature. The experimental results of Hammad et al. [18] are represented in this diagram for comparison. Fair agreement between the present predictions and the experimental data [18] is observed. The difference is of the same order of magnitude as that given in figure (8).

The effect of the desiccant solution temperature on the air humidity ratio reduction for desiccant solution concentration of 25% is depicted in Fig. (10). It is noticed from the figure that the air humidity ratio reduction decreases with increasing the desiccant solution

THEORITICAL STUDY FOR COMPACT LIQUID DESICCANT DEHUMIDIFIER/REGENERATOR SYSTEM

temperature. Good agreement between the present predictions and the experimental results of Hammad et al. [18] is observed.

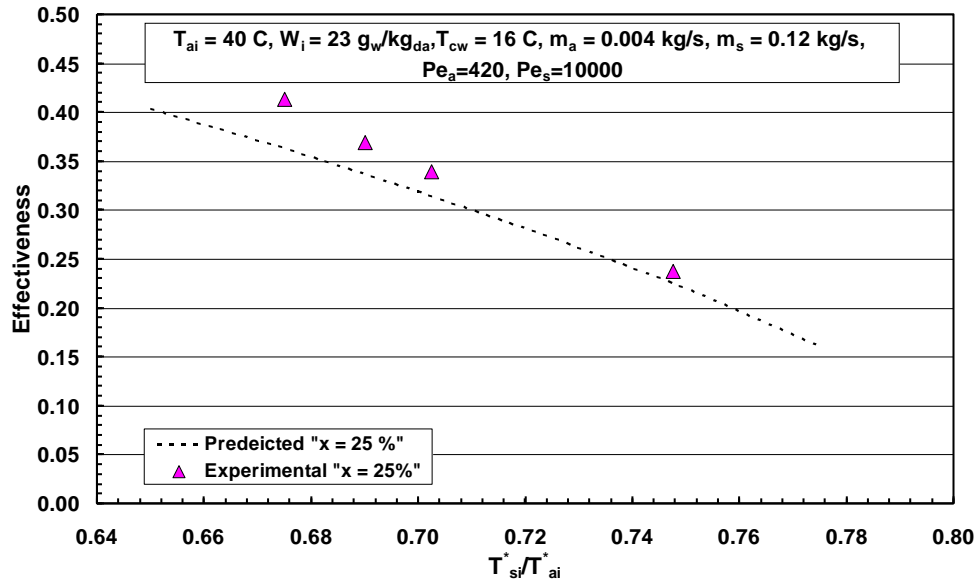

Fig. (8) The influence of the desiccant solution inlet temperature on the dehumidifier effectiveness

The effect of the desiccant solution/air mass flow rate ratio for desiccant solution concentration of 35% on the dehumidifier effectiveness is illustrated in Fig. (11). It is observed from the figure that the dehumidifier effectiveness increases with the increasing of the desiccant solution/air mass flow rate ratio. The results of Hammad et al. [18] are represented in this diagram for comparison. These results are in good agreement with the present work for the parameters studied, the maximum difference being about 9.3% at the highest (L/G) ratio of 20.

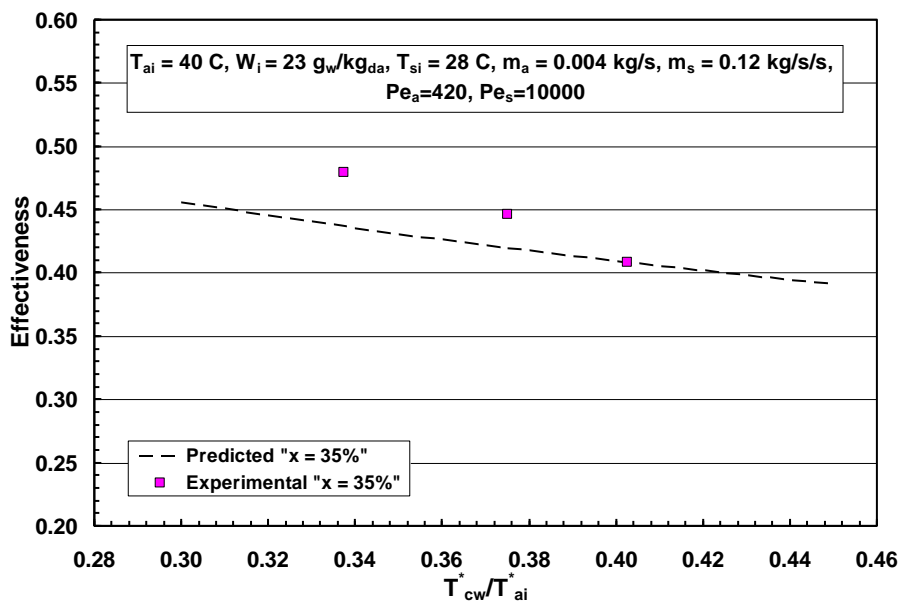

Fig. (9) The influence of the cooling water inlet temperature on the dehumidifier effectiveness

THEORITICAL STUDY FOR COMPACT LIQUID DESICCANT DEHUMIDIFIER/REGENERATOR SYSTEM

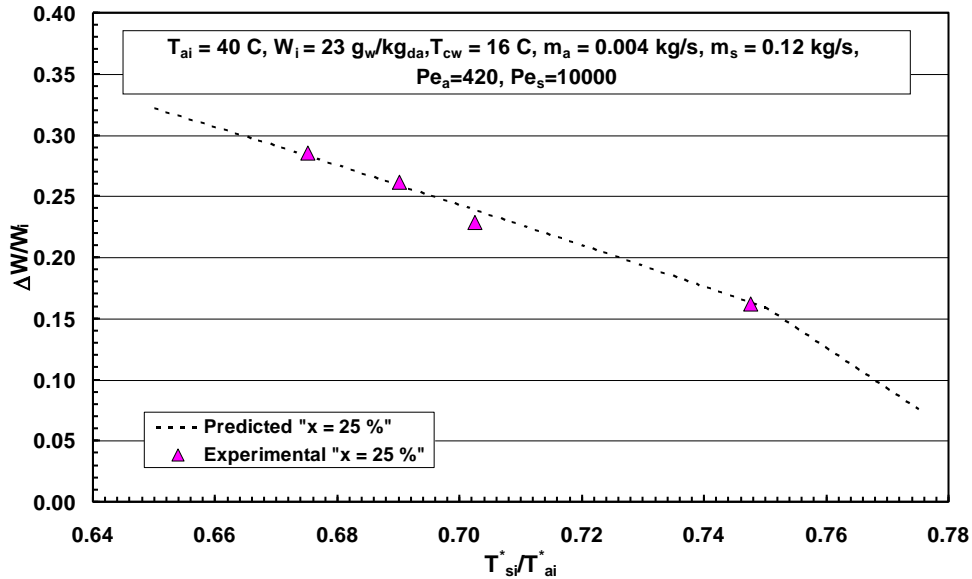

Fig. (10) The influence of the desiccant solution inlet temperature on the air humidity ratio reduction

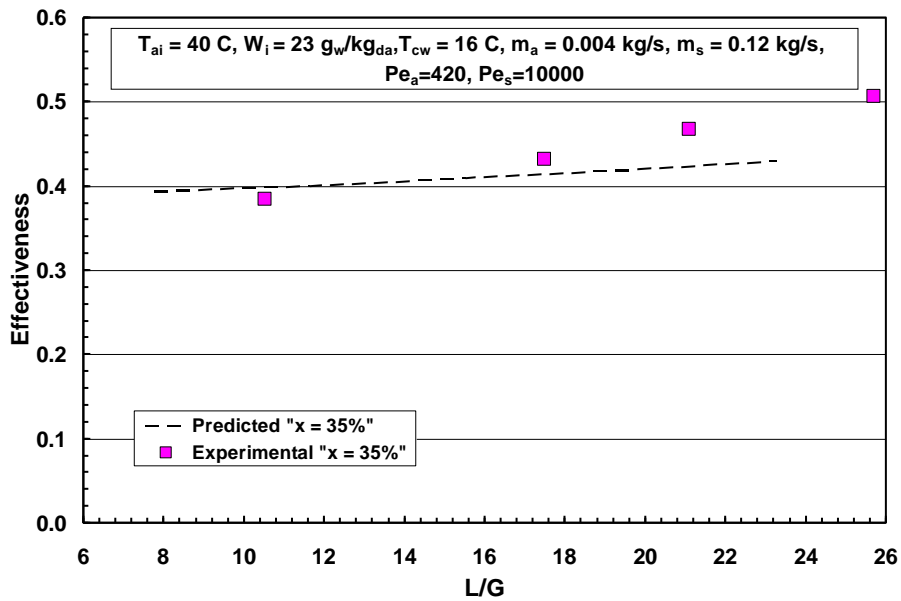

Fig. (11) The influence of the desiccant solution/air mass flow rate ratio on the effectiveness

4. RESULTS AND DISCUSSIONS:

The effect of various parameters of air and desiccant solution, mainly, air inlet temperature, air inlet humidity ratio, air mass flow rate, desiccant solution temperature, desiccant solution mass flow rate, desiccant solution to air mass flow rate ratio and desiccant concentration as well as cooling and heating water temperatures was investigated. Also, the present work studies the effect of the dimensionless groups mentioned in the dimensionless governing equations on the system performance. The various dimensionless groups appearing in equations (32) to (35) are calculated from the physical operating parameters given on the top of each figure that follows in the next discussions. The effect of each parameter is analyzed as follows:

4.1 The dependent Variables Distributions along Dehumidifier Height:

In this part of results, the local values for the four dependent variables of the governing equations W , ζ , T_a , T_s are presented. Figure (12) shows the variation of the air humidity ratio along the dehumidifier height at different desiccant solution concentrations. At any height, i.e. at any (z/H) the air humidity ratio is higher for lower concentrations. Also, the increasing in the desiccant solution concentration leads to a decrease of the air humidity ratio leaving the dehumidifier. This is because as the desiccant solution concentration increases the vapor pressure of the desiccant solution decreases and therefore a higher driving force for mass transfer between phases is attained.

The distribution of the moisture content at different desiccant solution temperatures along the dehumidifier height is illustrated in Fig. (13). As expected the desiccant moisture content increases with height. This increase is due to the water vapor absorption by the desiccant from the air acting the required dehumidification of the air. However, it is observed from this figure that, the moisture content at the dehumidifier exit decreases with increasing the desiccant solution temperature. It may be explained as follows: increasing the desiccant solution temperature increases the surface vapor pressure of the desiccant solution. The outlet air humidity ratio increases, which lead to decrease the moisture content of the desiccant solution. At all the desiccant temperatures, the rate of increase of the desiccant moisture content is high at the early stages of the dehumidifier up to (z/H) values of 0.5 after which this rate of increase becomes insignificant as shown in figure (13).

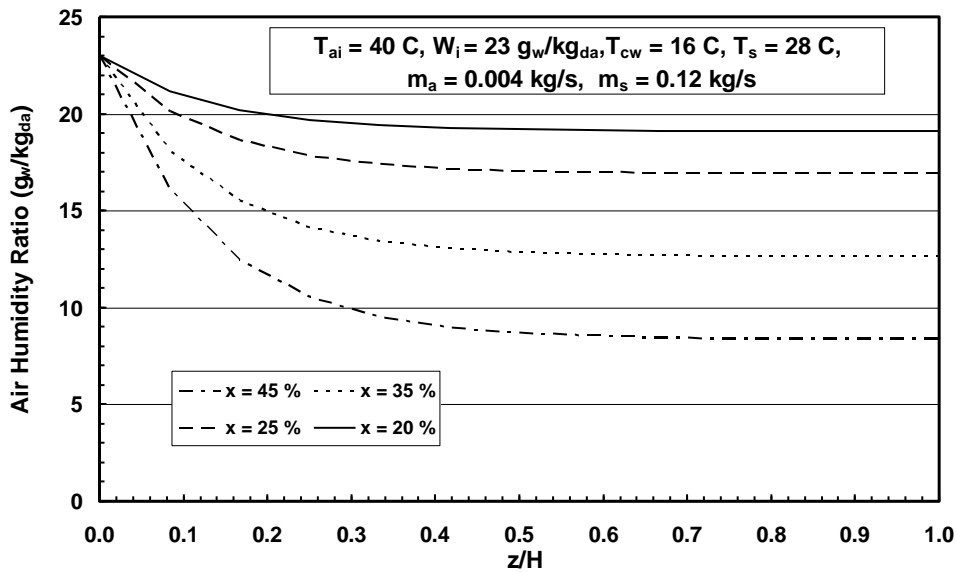

Fig. (12) The distribution of the air humidity ratio along the dehumidifier height at different values of desiccant solution concentrations

The distribution of the air temperature along the dehumidifier height at different desiccant solution concentrations is illustrated in Fig. (14). The air temperature at the outlet of the dehumidifier decreases with the increasing of desiccant solution concentration. This is because as the desiccant solution concentration increases the vapor pressure of the desiccant solution decreases and therefore higher driving force between the phases for mass transfer results and this leads to the decreasing of outlet air temperature. This decrease in the air temperature is due to the effect of the simultaneous exchange of heat and mass between the humid air and the solution. At the same air inlet temperature and the inlet humidity ratio, the decrease of the vapor pressure of the desiccant solution means a lower temperature at the humid air-sorbent interface. In this case, the rate of heat transfer from the humid air to the sorbent solution increases. As a consequence, the rate of water vapor condensation from the

THEORITICAL STUDY FOR COMPACT LIQUID DESICCANT DEHUMIDIFIER/REGENERATOR SYSTEM

humid air onto the interface increases. In such a case the drop in the air temperature will be higher as shown in figure (14). Also, the moisture content of the solution becomes higher as shown in figure (13) due to the higher interfacial condensation of the water vapor which diffuses rapidly into the solution due to its high affinity to water vapor.

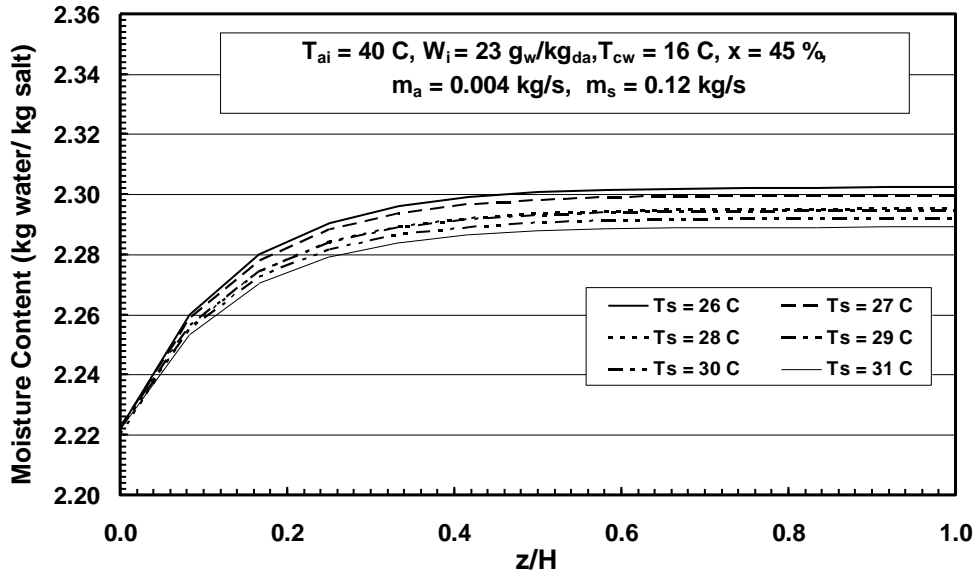

Fig. (13) The distribution of the moisture content along the dehumidifier height at different values of desiccant solution temperatures

The distribution of desiccant solution temperature along the dehumidifier height at different desiccant solution concentrations is presented in Fig. (15). It is observed from this figure that the desiccant solution temperature at dehumidifier outlet decreases with the increasing of the desiccant solution concentration. This is because as the desiccant solution concentration increases the vapor pressure of the desiccant solution decreases and therefore higher driving force between the phases for mass transfer results which cause decreasing of desiccant solution temperature

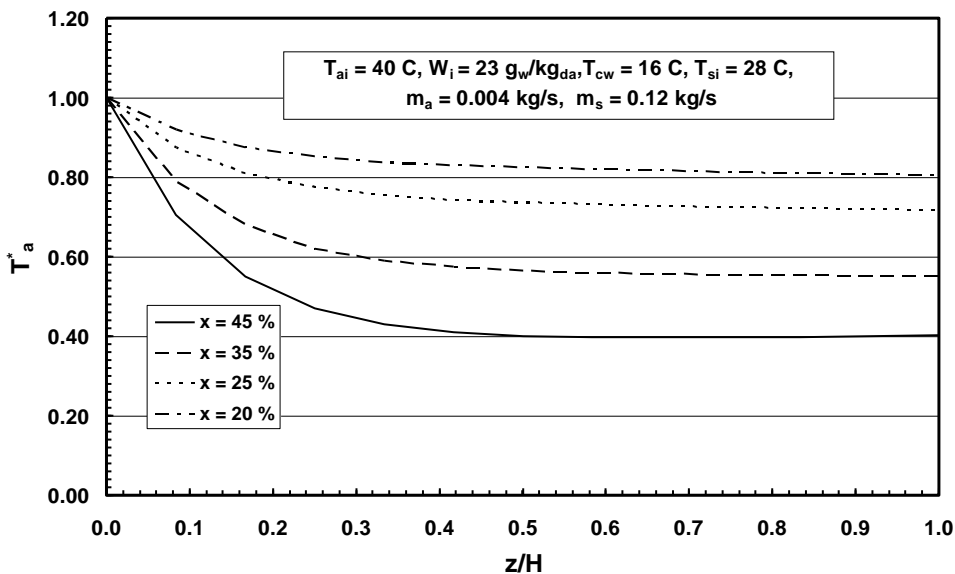

Fig. (14) The distribution of the dimensionless air inlet temperature along the dehumidifier height at different desiccant solution concentrations

THEORITICAL STUDY FOR COMPACT LIQUID DESICCANT DEHUMIDIFIER/REGENERATOR SYSTEM

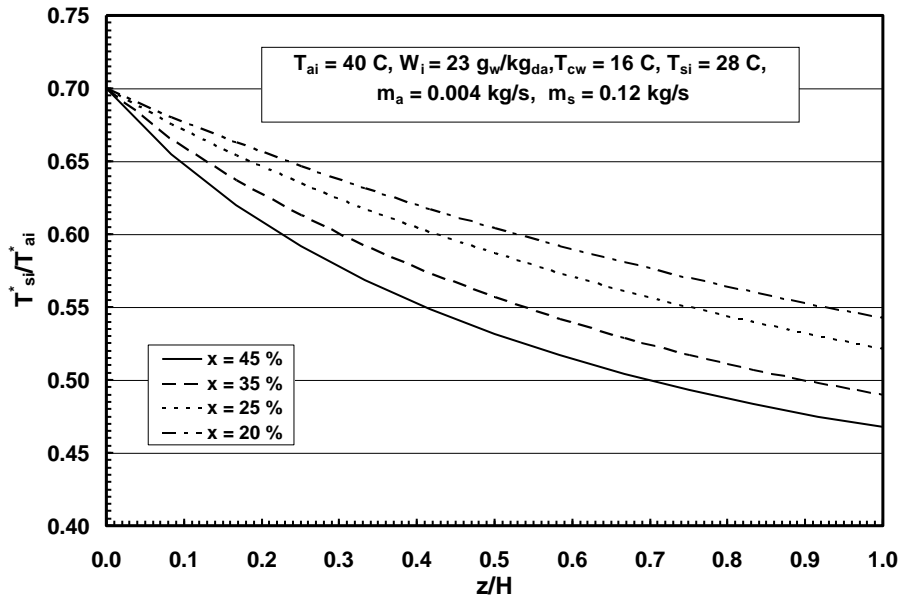

Fig. (15) The distribution of the dimensionless desiccant solution temperature at different desiccant solution concentrations along the dehumidifier height

4.2 The effects of operation parameters on the dehumidifier performance indices:

The desiccant solution moisture gain, the air humidity reduction ratio and the dehumidifier effectiveness are chosen as performance indices for the air dehumidifier. For the sake of brevity, the effect of any operating parameter is illustrated for only two of them.

4.2.1 The effect of the desiccant solution inlet temperature:

Figure (16) shows the effect of the desiccant solution inlet temperature on the air humidity ratio reduction at different values of the desiccant solution concentration. Increasing the desiccant solution temperature causes for each desiccant solution concentration a decrease in the air humidity ratio reduction due to the increase in the vapor pressure of the desiccant solution that results in a lower mass transfer rate.

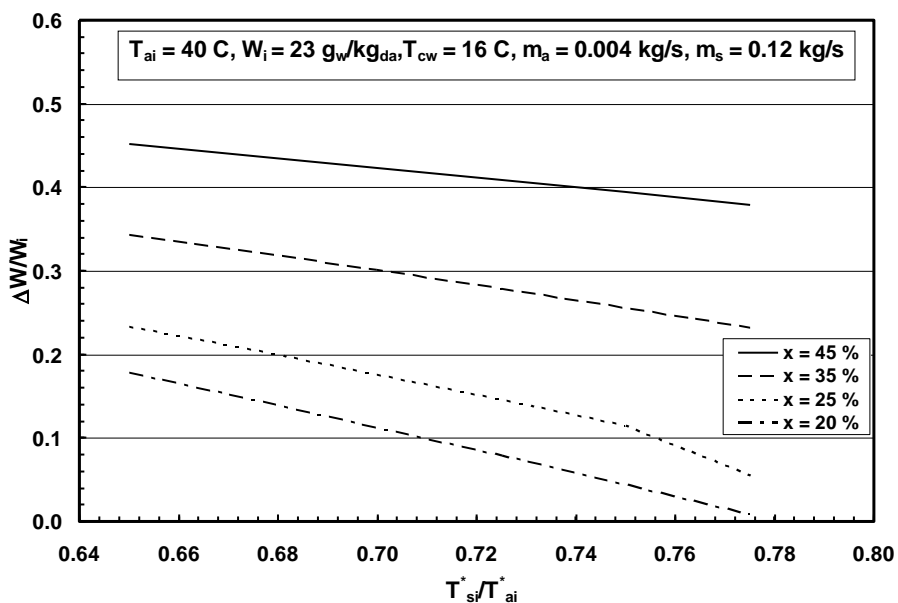

Fig. (16) The influence of the desiccant solution inlet temperature on the air humidity ratio reduction

THEORITICAL STUDY FOR COMPACT LIQUID DESICCANT DEHUMIDIFIER/REGENERATOR SYSTEM

Figure (17) illustrates the effect of the desiccant solution temperature on the effectiveness at different values of desiccant solution concentrations. Increasing the desiccant solution temperature causes a decrease in the effectiveness due to the increase in the vapor pressure of the desiccant solution that leads to lower mass transfer rate for each desiccant solution concentration.

Figures (16) and (17) reveal that as the desiccant solution inlet temperature increases both of the humidity reduction ratio and the humidifier effectiveness decreases which is in conformity with the experimental results discussed before in figures (8), (9) and (10).

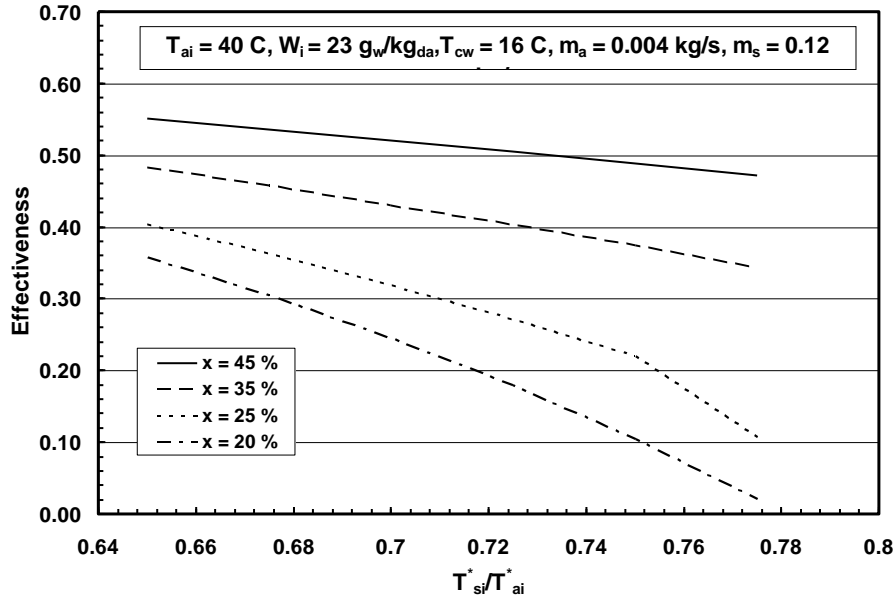

Fig. (17) The influence of the desiccant solution inlet temperature on the dehumidifier effectiveness

4.2.2 The Effect of the air inlet temperature:

The effect of the air inlet temperature on the air humidity ratio reduction at various values of the desiccant solution concentration is illustrated in Fig. (18). Increasing the air inlet temperature for all desiccant solution concentrations leads to insignificant changes in the air humidity ratio reduction.

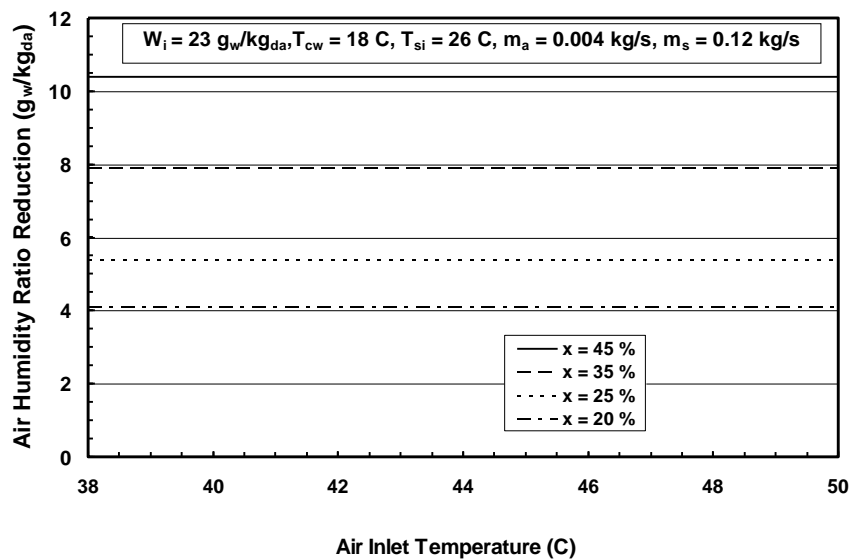

Fig. (18) The influence of the air inlet temperature on the air humidity ratio reduction

THEORITICAL STUDY FOR COMPACT LIQUID DESICCANT DEHUMIDIFIER/REGENERATOR SYSTEM

The effect of the air inlet temperature on effectiveness at various values of the desiccant solution concentration is depicted in Fig. (19). Increasing the air inlet temperature for each desiccant solution concentration does not cause significant effect on the dehumidifier effectiveness.

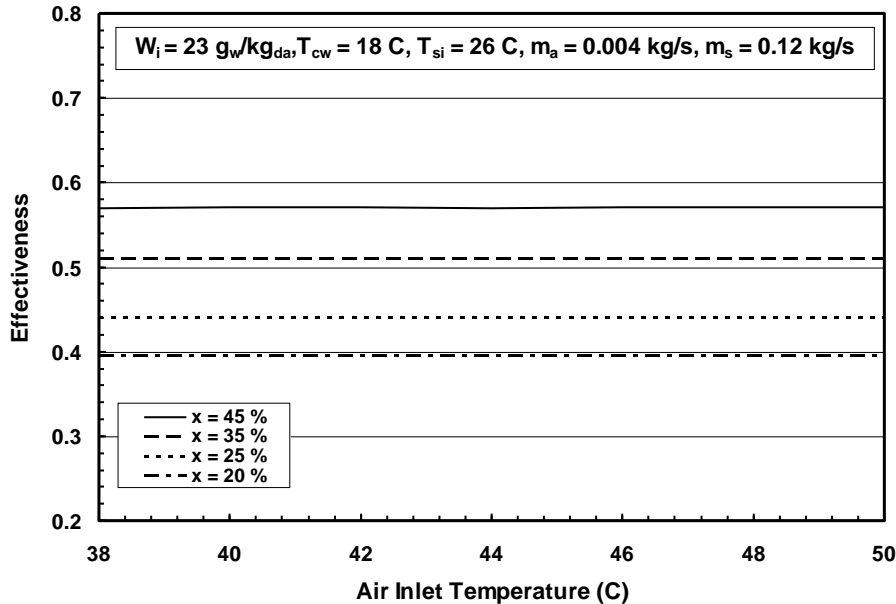

Fig.(19) The influence of the air inlet temperature on the dehumidifier effectiveness

4.2.3 The effect of the air inlet humidity ratio:

The effect of the air inlet humidity ratio on the air humidity ratio reduction at various values of the desiccant solution concentration is shown in Fig. (20). Increasing the air inlet humidity ratio for each desiccant solution concentration causes an increase in the humidity ratio reduction due to the increase in the water vapor pressure of the humid air that results in a higher mass transfer rate. The reduction in the humidity ratio is more pronounced for higher solvent concentrations being 0.43 at 45% concentration compared to 0.13 at 20% concentration while the air inlet humidity ratio was 21 ($\text{g}_w/\text{kg}_{d.a.}$) in both cases.

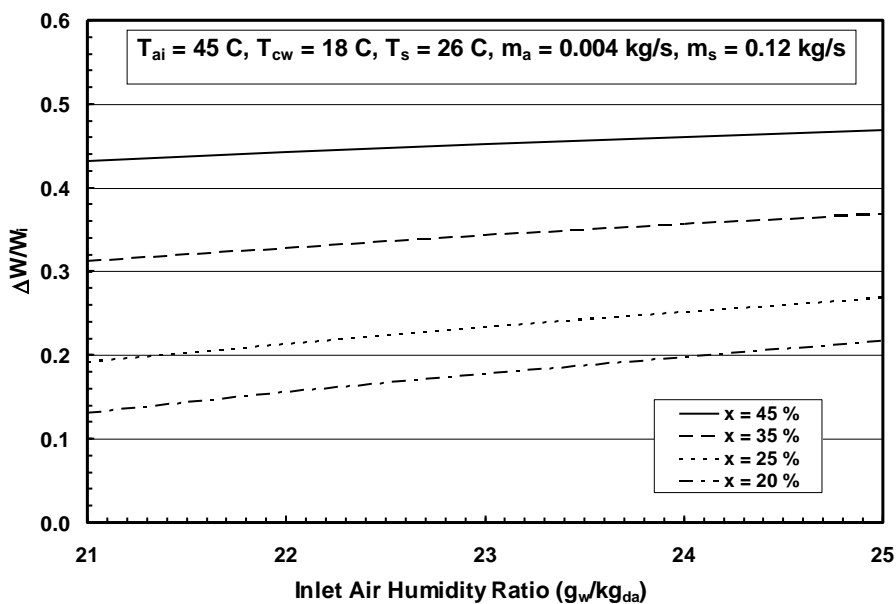

Fig. (20) The influence of air the inlet humidity ratio on the air humidity ratio reduction

The effect of the air inlet humidity ratio on the dehumidification effectiveness at different values of desiccant solution concentrations is illustrated in Fig. (21). Increasing the air inlet humidity ratio for each desiccant solution concentration causes an increase in the effectiveness due to the increase in the vapor pressure of the desiccant solution.

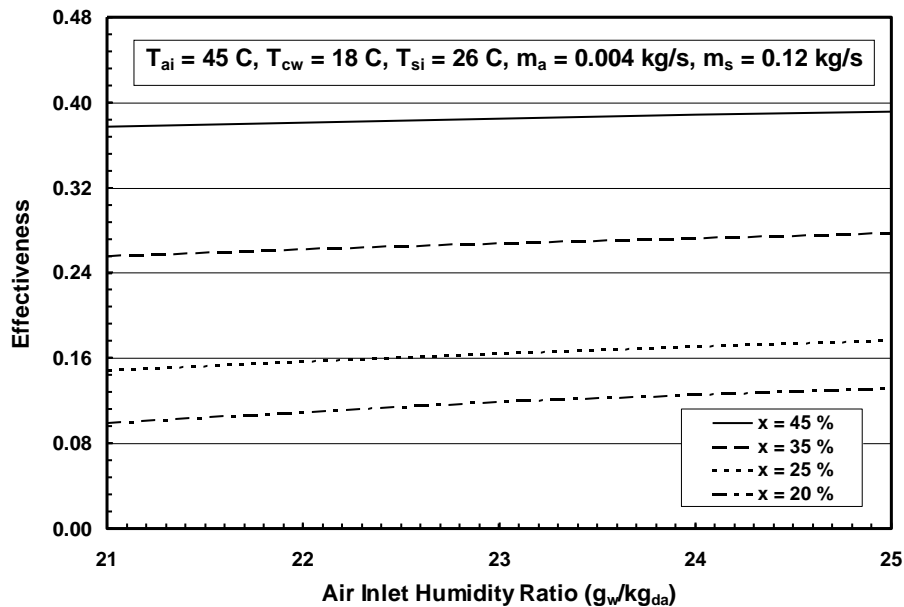

Fig. (21) The influence of the air inlet humidity ratio on the effectiveness

4.2.4 The effect of the desiccant solution /air mass flow rates ratio:

The effect of the desiccant solution to the air mass flow rates ratio (L/G) on the moisture content gain at various values of the desiccant solution concentrations is illustrated in Fig. (22). It is noticed from the figure that, the desiccant solution moisture content gain decreases with increasing the desiccant solution mass flow rate. The effect can be explained as follows: with the desiccant solution mass flow rate increasing, the variation of the desiccant solution concentration through the dehumidifier decreases and the variation of the surface vapor pressure decreases, and hence increasing the average water vapor pressure difference between the desiccant solution and the air in the dehumidifier. Increasing the desiccant solution flow rate also increases the mass transfer coefficient between the desiccant solution and the air in the dehumidifier. This increase in both of the driving potential differences, i.e. the mass transfer coefficient and the difference in the water vapor pressure causes an increase in the rate of moisture absorption by the absorbent but at a rate lower than the increase of the mass flow rate of the solution. For these reasons the ratio of the increase of the moisture content of the solution decreases with the increase of its mass flow rate. This is due to the well known fact that the increase in any transport phenomenon, such as in heat or mass transfer, with the mass flow rate follows an exponential relationship in which the exponent is less than unity.

THEORITICAL STUDY FOR COMPACT LIQUID DESICCANT DEHUMIDIFIER/REGENERATOR SYSTEM

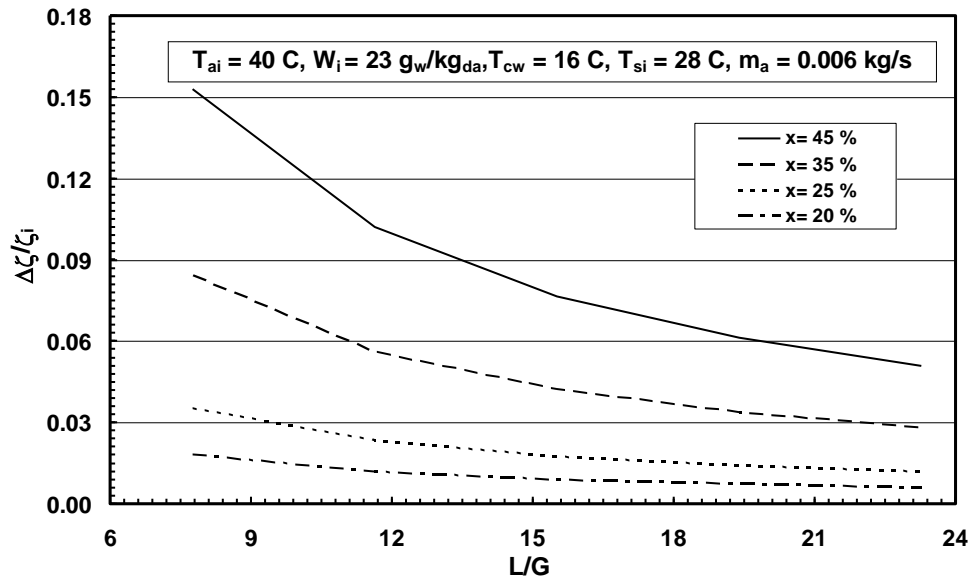

Fig. (22) The influence of the desiccant solution/air mass flow rates ratio on the desiccant solution moisture content gain ratio

Figure (23) shows the effect of the desiccant solution/air mass flow rate ratios on the effectiveness at different values of desiccant solution concentrations. It is noticed from the figure that, the effectiveness slightly increases with the increasing desiccant solution mass flow rate. This can be explained as follows: with the desiccant solution mass flow rate increasing, the variation of the desiccant solution concentration through the dehumidifier decreases and the variation of the surface vapor pressure decreases, and hence causing a lower decrease in the average water vapor pressure difference between the desiccant solution and the air in the dehumidifier.

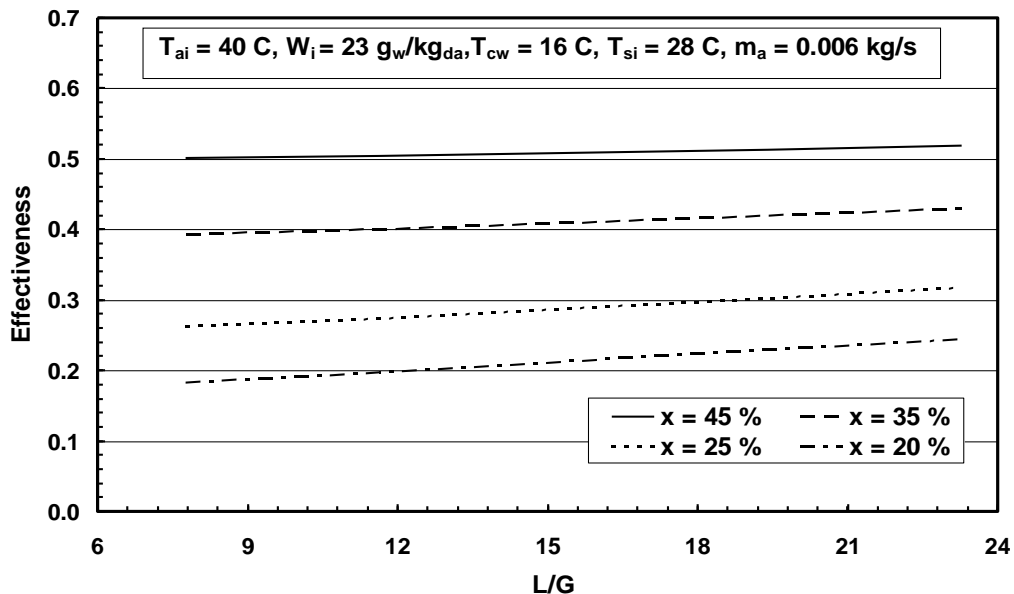

Fig. (23) The influence of the desiccant solution/air mass flow rates ratio on the dehumidifier effectiveness

4.3 The effects of Dimensionless Groups on the Dehumidifier Performance Indices:

Among the various dimensionless groups which are pre-mentioned in the dimensionless form of the governing equations, only four groups are having a significant effect on the dehumidifier performance. The four groups are the air Peclet number Pe_a , the solution Peclet number Pe_s , the air equilibrium humidity ratio G_1 , and R_5 which is defined by ($R_5=k_a c_p_s/k_s c_p_a=R_3/R_4$).

Figure (24) shows the distribution of the desiccant solution moisture content ratio at different air Peclet numbers along the dehumidifier height. Increasing the air Peclet number leads to an increase of the desiccant solution moisture content leaving the dehumidifier. In the solution temperature range encountered in these calculations the variation of the Peclet number will be mainly due to the variation in Reynolds number, Re , rather than the variation of Prandtl number, Pr . However, the increase in both Re or Pr leads to an increase of both of the heat and mass transfer coefficients and increasing both of the rate of heat and mass transfer.

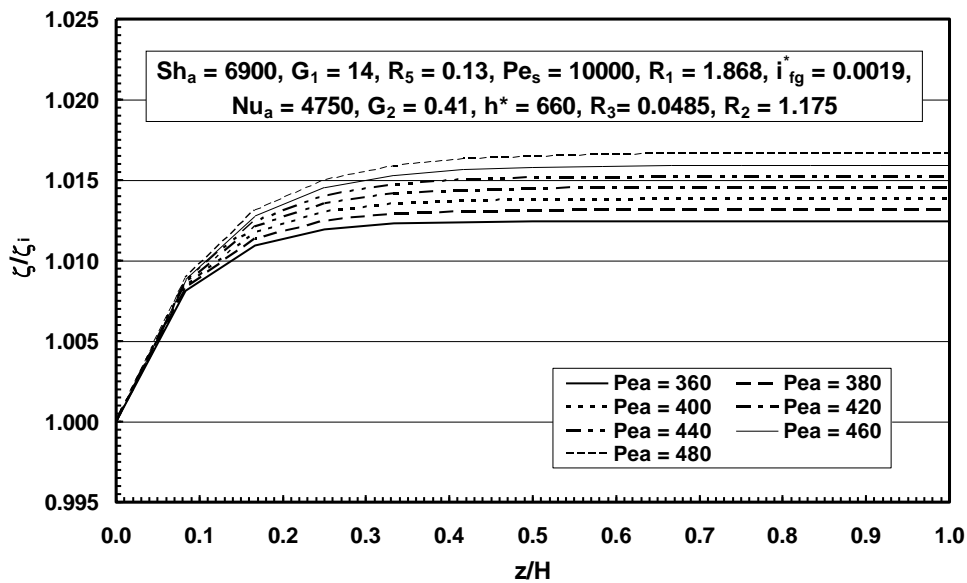

Fig. (24) The distribution of the desiccant solution moisture content ratio along the dehumidifier height at different air Peclet numbers

The distribution of the air humidity ratio reduction along the dehumidifier height at different equilibrium humidity ratio conditions of air in contact with the desiccant solution is shown in Fig. (25). It is observed from this figure that the air humidity ratio reduction at the exit of the dehumidifier increases with decreasing the equilibrium humidity ratio condition which is defined as the condition at which both the air and the desiccant are in equilibrium, i.e. no heat or mass transfer occurs between air in contact with desiccant solution.

The distribution of the desiccant solution moisture content ratio along the dehumidifier height at different values of ($R_5=k_a c_p_s/k_s c_p_a=R_3/R_4$) is shown in Fig. (26). It is observed from this figure that the desiccant solution moisture content at leaving the dehumidifier increases with increasing R_5 .

The distribution of the desiccant solution moisture content ratio along the dehumidifier height at various values of the solution Peclet numbers is illustrated in Fig. (27). It is observed from this figure that the desiccant solution moisture content at leaving the dehumidifier increases with decreasing the solution Peclet number. This is due to the fact that decreasing the Peclet number is caused by a decrease in the mass flow rate which is higher than the resultant decrease in both of the interfacial heat and mass transfer because the

THEORITICAL STUDY FOR COMPACT LIQUID DESICCANT DEHUMIDIFIER/REGENERATOR SYSTEM

relation between the Peclet number and the mass flow rate is almost linear while it is exponential with the interfacial mass transfer with an exponent less than unity.

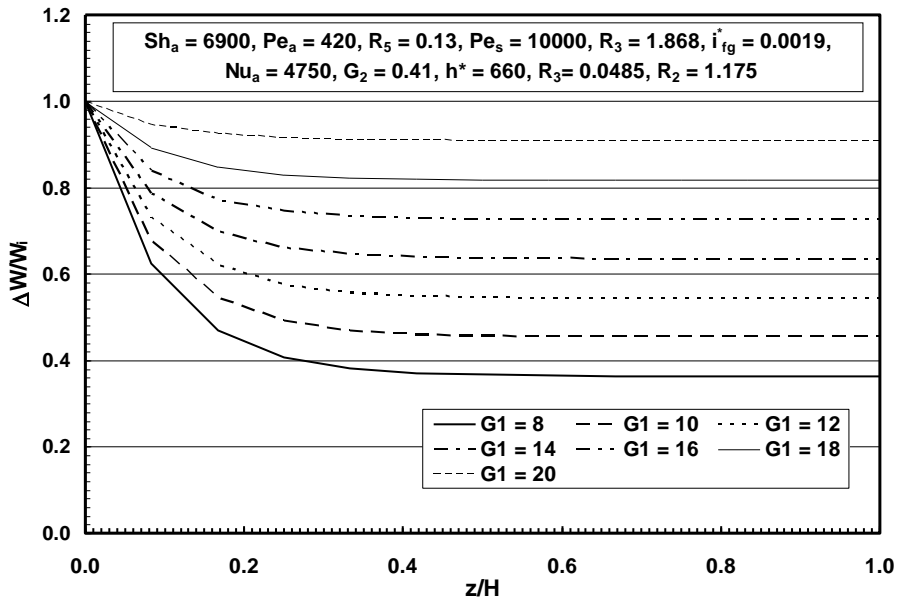

Fig. (25) The distribution of the air humidity ratio reduction along the dehumidifier height at different equilibrium humidity ratios conditions of air in contact with the desiccant solution

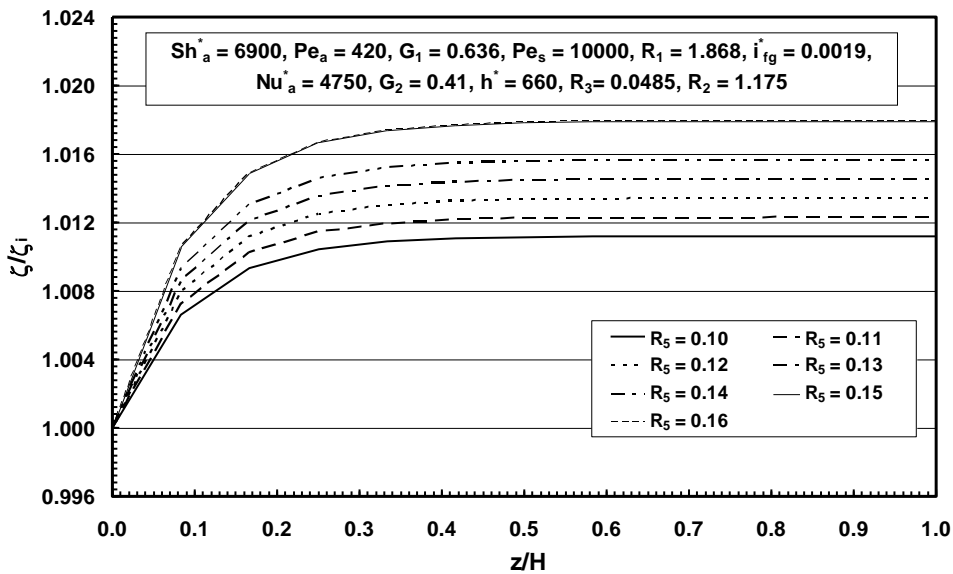

Fig. (26) The distribution of the desiccant solution moisture content along the dehumidifier height at different values of R_5

THEORITICAL STUDY FOR COMPACT LIQUID DESICCANT DEHUMIDIFIER/REGENERATOR SYSTEM

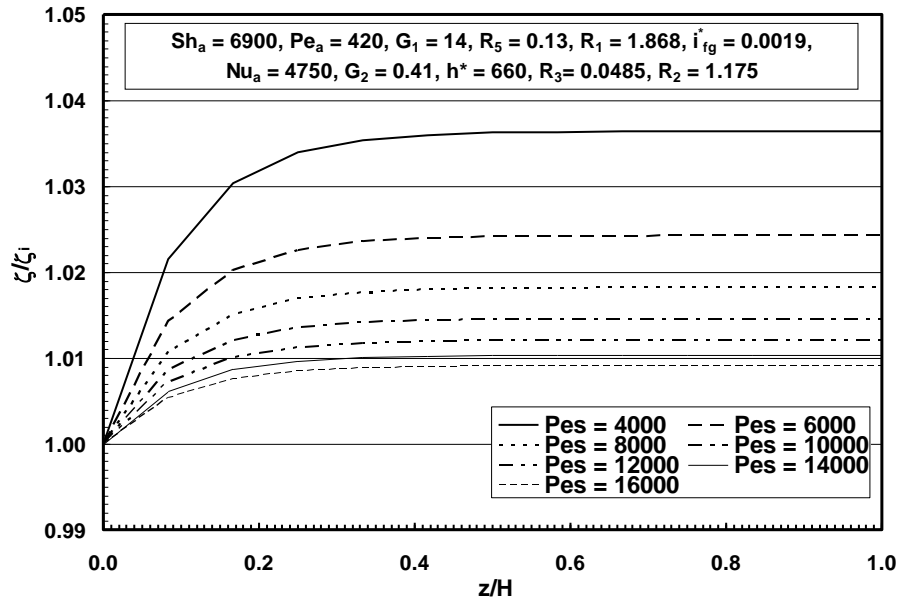

Fig. (27) The distribution of the desiccant solution moisture content along the dehumidifier height at different desiccant solution Peclet numbers

5. The conclusions:

The present analysis is used for deriving the governing equations to predict the variation of the humidity ratio of the air, the moisture content of the solution, the air temperature and the solution temperature along the dehumidifier height in the dehumidifier and heat exchanger sides. In view of what has been introduced the following conclusions can be drawn:

1. The air humidity ratio decreases along the dehumidifier height with increasing of the desiccant solution concentration, but with decreasing of desiccant solution temperature.
2. The desiccant solution moisture content decreases along the dehumidifier height with the increasing of the desiccant solution temperature and the mass flow rate, but with decreasing of the inlet humidity ratio.
3. The air temperature decreases along the dehumidifier height with the increasing of both of the desiccant solution concentration and the inlet humidity ratio, but with decreasing of the desiccant solution inlet temperature.
4. The desiccant solution temperature decreases along the dehumidifier height with the decreasing of any of the desiccant solution mass flow rate or the cooling water temperature, but with increasing of the desiccant solution concentration and is not affected with the inlet humidity ratio.
5. Only about 40% of the dehumidifier height is enough to get the maximum performance of the dehumidifier and save both fixed and operating costs for this design.
6. The desiccant solution moisture content gain increases with the increase of each of the desiccant solution concentration and the inlet humidity ratio, but it increases with the decrease of the desiccant solution temperature and the mass flow rate.
7. The desiccant solution moisture content gain increases with increasing of the air Peclet number and as well as with the air to desiccant solution thermal conductivity ratio/ the air to desiccant solution specific heat ratio, but it increases with the decreasing of the equilibrium humidity ratio condition of the air in contact with the desiccant solution and the solution Peclet number.
8. The air humidity ratio reduction decreases with the increase of the equilibrium air humidity ratio.

THEORITICAL STUDY FOR COMPACT LIQUID DESICCANT DEHUMIDIFIER/REGENERATOR SYSTEM

9. Both of the humidity reduction ratio and the dehumidifier effectiveness decreases with the increase of the cooling water temperature and the liquid desiccant solution temperature.
10. The inlet air temperature (the ambient air temperature) has insignificant effect on the dehumidifier performance indices. While the increase of the inlet air humidity ratio (ambient air humidity ratio) the humidity reduction ratio increases.
11. The increase of the air flow rate leads to decrease in the two performance indices of the dehumidifier which are the humidity reduction ratio and the dehumidifier effectiveness.
12. The increase of the liquid desiccant solution flow rate leads to an increase of the dehumidifier performance indices.
13. As the solution to air mass flow rate ratio increases the performance indices increases.
14. Both the performance indices increase with the increase of the liquid desiccant solution concentration.
15. The present theoretical work shows new compact design of high performance for the air dehumidifier-heat exchanger-regenerator liquid desiccant system whose performance was validated by comparing its analytical results with previously published experimental ones.

References

1. Lof, G. O. G., (1955), "Cooling with Solar Energy," Congress on Solar Energy Tucson, AZ, pp. 171-189.
2. Radhwan A. M., Gari H. N. and Elsayed M. M. (1993), "Parametric Study of a Packed Bed Dehumidifier / Regenerator Using Ca Cl₂ Liquid Desiccant," Renewable Energy, vol. 3, part 1, pp. 49 - 60.
3. Khan A. Y., and H. D. Ball, (1992), "Development of a Mathematical Model and Computer Simulation to Predict the Annual Energy Consumption of Coil-Type Liquid Desiccant Systems," ASHRAE Transactions, vol. 98, part 1, pp. 534-541.
4. Rix J., D. Nevrala, Chauvet L. and Probert S. D. (1993), "Gas-Powered Liquid Desiccant Dehumidifier," Applied Energy, vol. 45, pp. 167-180.
5. Ganadhidasan P., (2004), " A simplified model for air dehumidification with liquid desiccant," Solar Energy, vol. 76, pp. 409-416.
6. Chengqin, R., Yi, J., Guangfa, T. and Yianpin, Z. "A characteristic study of liquid desiccant dehumidification/regeneration process," Solar Energy, 79, 2005, pp.483-494.
7. Chengqin, R., Yi, J., Guangfa, T. and Yianpin, Z. "Simplified analysis of coupled heat and mass transfer processes in packed bed liquid desiccant air contact system," Solar Energy, 79, 2005, pp.483-494.
8. Pietruschka, D., Eicker, U., Huber, M. and Schumacher, J.," Experimental performance cooling systems for air conditioning in residential buildings," Int. J. of Refrigeration 29, (2006), pp.110-124.
9. Mesquita L. C. S., Harrison S. J. and Thomey D., (2006), "Modeling of Heat and Mass Transfer in Parallel Plate Liquid Desiccant Dehumidifiers," Solar Energy, vol. 80, No. 11, pp. 1475-1482.
10. Liu X., Jiang Y., Xia J. and Chang X., (2007), "Analytical solutions of coupled heat and mass transfer processes in liquid desiccant air dehumidifier/regenerator," Energy Conversion and Management, vol. 48, pp. 2221-2232.
11. Liu X.H., Jaing Y. and Qu, K.Y., (2007) "Heat and mass transfer model of cross flow liquid desiccant air dehumidifier/regenerator," Energy Conversion and Management, vol. 48, pp. 546-554.

THEORITICAL STUDY FOR COMPACT LIQUID DESICCANT DEHUMIDIFIER/REGENERATOR SYSTEM

12. Liu X.H., Jaing Y. and Qu, K.Y., (2008) "Analytical solution of combined heat and mass transfer performance in a cross flow packed bed liquid desiccant air dehumidifier," Int. J. Heat Mass Transfer, vol. 51, pp. 4563-4572.
13. Mohan B.S., Maiya M.P. and Tiwari S., (2008), "Performance characterisation of liquid desiccant column for a hybrid air conditioner," Applied Thermal Engineering, vol. 28, pp. 1342-1355.
14. Liu X.H. and Jiang Y., (2008), "Coupled heat and mass transfer characteristics in packed bed dehumidifier/regenerator using liquid desiccant," Energy Conversion and management, vol. 49, pp. 1357-1366.
15. Hassan, A.A.M. and Hassan, M.S., (2008), "Dehumidification of air with a newly suggested liquid desiccant," Renewable Energy, vol. 33, pp. 1989-1997.
16. Ren C. Q., Tu M. and Wang H. H., (2007), "An Analytical Model for Heat And Mass Transfer Processes in Internally Cooled or Heated Liquid Desiccant–Air Contact Units," International Journal of Heat and Mass Transfer, vol. 50, pp. 3545–3555.
17. Jain S. and Bansal P. K., (2007), "Performance Analysis of Liquid Desiccant Dehumidification Systems," International Journal of Refrigeration, vol. 30, pp. 861-872.
18. Hammad M.M., El-Ghanam R. I., Sakr R.Y., Ayad, S.S., (2008), " Experimental study for compact liquid desiccant dehumidifier/regenerator system", Engineering Research Journal, Vol. 116, April M1-M28, Helwan University.
19. ASHRAE, ASHRAE Handbook of Fundamentals, (2005).
20. Dow Chemical Company, Calcium Chloride Properties and Forms Handbook. Dow Chemical Company, U.S.A (1983).
21. Trebal, R.E., 1980, Mass-Transfer Operation, McGraw Hill, Chapter 6.

Nomenclature:

Symbols	Description	Units
A	cross sectional area	m^2
A_h	heat transfer area per unit effective volume	m^2/m^3
A_m	average specific interfacial surface area for mass transfer	m^2/m^3
A_t	surface area of tubes per unit effective volume	m^2/m^3
a	half width of the space for heat exchanger	m
b	width of the element	m
cp	specific heat at constant pressure	$J / kg \cdot ^\circ C$
D	characteristic length for Reynolds and Nusselt numbers calculations	m
d	outside tube diameter	m
d_b	average bubble diameter	m
dz	height of the control volume	m
g	acceleration of gravity	m / s^2
$G_1 = W_e^*$	dimensionless equilibrium air humidity ratio	-----
$G_2 = T_w^*$	dimensionless temperature of tube wall	-----
H	height	m
h_a	heat transfer coefficient between the process air and the desiccant interface	$W / m^2 \cdot K$
h_t	heat transfer coefficient between the humidifier solution and the cold tube matrix	$W / m^2 \cdot K$
h_D	mass transfer coefficient between the process air and the humidifier liquid desiccant	m / s

THEORITICAL STUDY FOR COMPACT LIQUID DESICCANT DEHUMIDIFIER/REGENERATOR SYSTEM

i	enthalpy,	J / kg
i_{fg}	latent heat of evaporation for water	J / kg
$i_{fg,0}$	latent heat of evaporation for water at 0 °C	J / kg
k	thermal conductivity	W / m K
L	length of the shell	m
m	mass flow rate	kg / s
n	number of air distributer holes	–
N	number of dehumidifier water tubes	
Nu_a^*	modified Nusselt number, $Nu_a^* = z_r^2 h_a A_m (1 - \phi_{wt}) / k_a$,	–
p	pressure	kPa
Pe	Peclet number, $Pe = Pr.Re$	
Pr	Prandtl number, $\mu cp/k$	-
p_{sat}	saturation pressure of water vapor at dry bulb temp. of the air	kPa
P_x	saturation pressure of the solution of concentration x at the desiccant solution temperature	kPa
P_{w0}	saturation pressure of pure water (i.e. $x = 0$) at the desiccant solution temperature	kPa
P_{wx}	saturation pressure of the desiccant solution of concentration x at the desiccant solution temperature	kPa
q_a	heat transfer from air to solution	W
q_w	energy transfer by mass transfer of water vapor	W
R	shell radius	m
R_1	water vapor to air specific heat ratio, cp_v/cp_a	
R_2	water to desiccant solution specific heat ratio, cp_w/cp_s	-----
R_3	air to desiccant solution thermal conductivity ratio, k_a/k_s	-----
R_4	air to desiccant solution specific heat ratio, cp_a/cp_s	-----
$R_5 = R_3/R_4$	$(k_a/k_s).(cp_s/cp_a)$	-----
R_a	air gas constant	J / kg.K
Re	Reynolds number, $\rho Du/\mu$	-----
Sc	Schmidt number, $\mu/\rho\alpha$	-----
Sh	Sherwood number, $h_D d_b/\alpha$	-----
Sh^*	modified Sherwood number, $Sh_a^* = z_r^2 h_D A_m (1 - \phi_{wt}) / \alpha_a$	–
S_x	longitudinal pitch	m
S_z	transverse pitch	m
T	temperature	°C
T_o	reference temperature	°C
u	actual velocity	m / s
W	humidity ratio of the air	kg _w /kg _{d.a}
x	desiccant solution concentration	kg _{salt} /kg _{solution}
z	location of any point in the shell measured from the lowest location on the circumference of the shell	m

Superscripts:

* dimensionless value or modified . rate

Subscripts:

a air r reference
 b bubble s sorbent / solution

THEORITICAL STUDY FOR COMPACT LIQUID DESICCANT DEHUMIDIFIER/REGENERATOR SYSTEM

e	equilibrium condition	<i>sat</i>	saturation
<i>h/cw</i>	hot / cold water	<i>t</i>	tube
<i>he</i>	heat exchanger	<i>v</i>	water vapor
<i>l</i>	liquid	<i>w</i>	water, also wall
<i>o</i>	orifice	<i>wt</i>	water tubes

Greek Symbols:

α	diffusivity	m^2/s
μ	dynamic viscosity	Pa. s
Δ	reduction	
ρ	density	kg / m^3
φ	void of tubes	-----
ζ	moisture content of desiccant solution	kg_{H_2O} / kg_{salt}
ε	dehumidifier effectiveness, $\varepsilon = (W_i - W_o) / (W_i - W_e)$	-----